

Concrete pad 70" x 120"

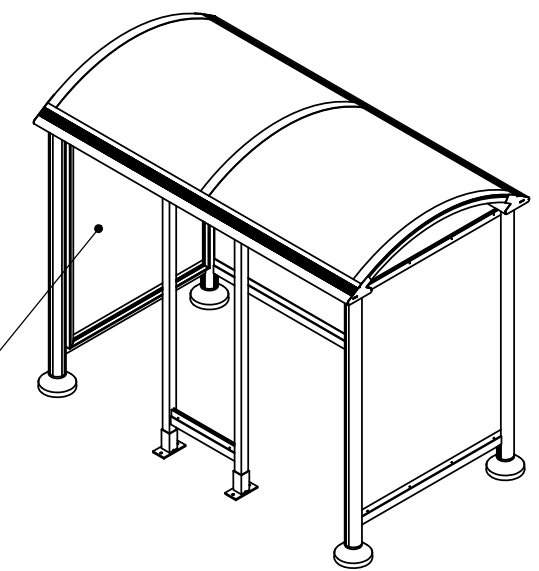

DISPLAY CASE
51 1/2" x 72 1/2"

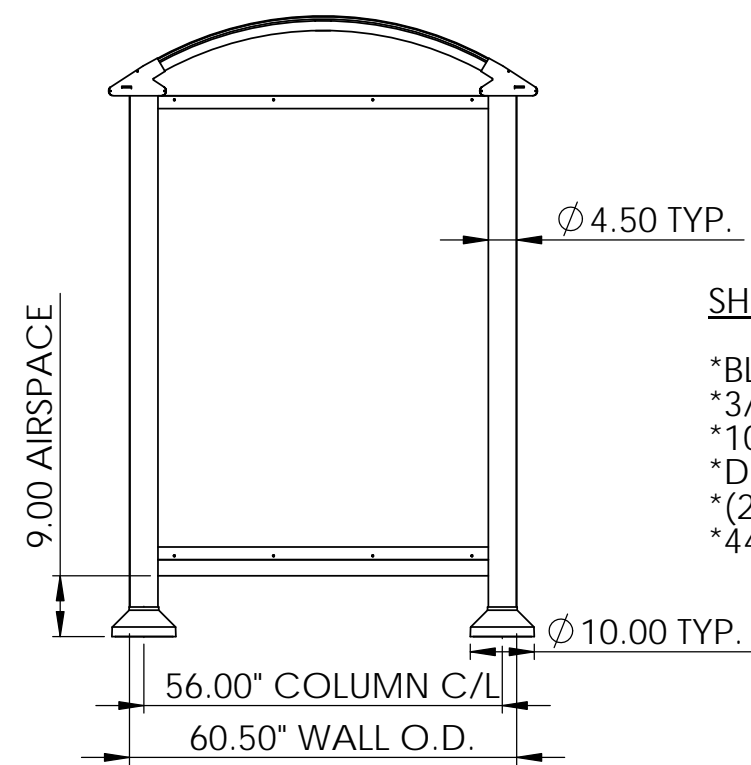
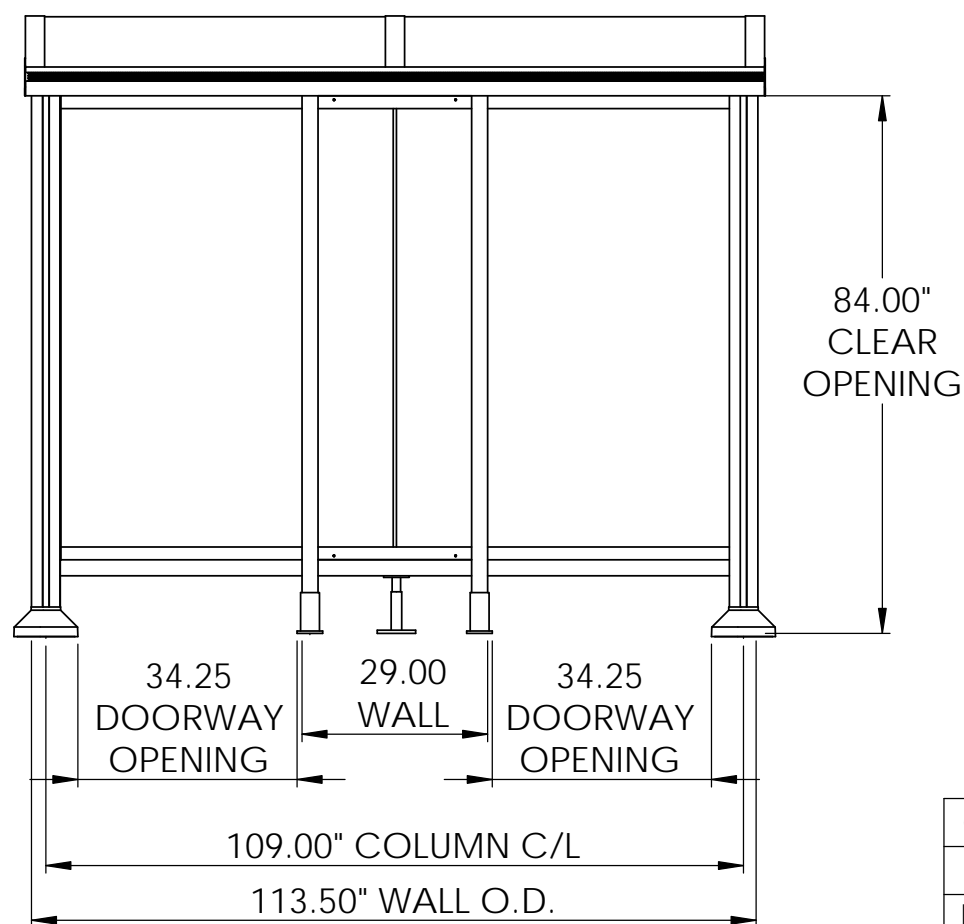

SHELTER NOTES:

- *BLACK ANODIZED FINISH
- *3/8" CLEAR TEMPERED GLASS PANELS
- *10MM BRONZE POLYCARBONATE ROOF PANELS (PCSS)
- *DISPLAY CASE - FULL LEFT WALL
- * (2) 5 WATT LED PUCK LIGHTS MOUNTED IN ROOF
- *44" FREE STANDING BENCH (SEE SEPERATE SHEET)

Client:	Project:	UNLESS OTHERWISE SPECIFIED: DIMENSIONS ARE IN INCHES TOLERANCES: FRACTIONAL ± ANGULAR: MACH ± BEND ± TWO PLACE DECIMAL ± THREE PLACE DECIMAL ±	NAME	DATE	Duo-Gard Industries, Inc. TITLE: GRAND-GARD MODEL 5 X 9	
	GREATER PORTLAND TRANSIT DISTRICT		DRAWN	RC		8/28/15
PROPRIETARY AND CONFIDENTIAL: THE INFORMATION CONTAINED IN THIS DRAWING IS THE SOLE PROPERTY OF <i>Duo-Gard Industries, Inc.</i> ANY REPRODUCTION IN PART OR AS A WHOLE WITHOUT THE WRITTEN PERMISSION OF <i>Duo-Gard Industries, Inc.</i> IS PROHIBITED.		INTERPRET GEOMETRIC TOLERANCING PER:	REVISED	RC		9/30/15
		MATERIAL	REVISED	RC		10/14/15
		FINISH	MFG APPR.			
APPLICATION		ALUMINUM	Q.A.			
		BLACK ANODIZED	COMMENTS:			
		DO NOT SCALE DRAWING				

SIZE	DWG. NO.	REV
B		2
SCALE: 1:50		WEIGHT: 462.35
SHEET 2 OF 10		